

FRC Global

Alumina Graphite





Expert Teams.



Quality Products.



Global Networks.

Who We Are

FRC Global is a leading supplier of refractories, electrodes, and high temperature combustion systems. FRC Global provides outstanding results for our clients within the iron, steel, and non-ferrous industries. Our company's reputation is built by delivering high quality products made with premium raw materials. We are more global now than ever before.

We give you a competitive advantage by offering you superior proven products that positively impact your bottom line and perform better. Our knowledgeable engineers ensure the proper application of our products to give you the maximum level of output and safety.

With over 25 warehouse facilities in the United States, Canada, Mexico, and South America we assure your products are readily available when you need them in these regions.

Through the use of vast global resources, all of us at FRC Global are committed to being the value creators and problem solvers for our industry.



Our Mission

Embrace modern technology to increase innovation, efficiency, and transparency. Inspire the next generation by driving change, promoting curiosity, and shaping sustainable solutions in the high temp world.





About Us

Background Information

FRC Global is a second generation family owned company with a 30-year history.

Global Offices

FRC Global has offices, agents, or partners in 20 countries around the world.

- North America: United States and Canada
- South America: Colombia
- Asia: China

We provide quality engineered products and services for all your high temperature applications.

FRC Global facts

Our quality control employees thoroughly inspect shipments to ensure products are within specification and are properly packaged.

Sales force and service needs are available in the following:

- North America
- Central America
- South America
- Europe
- Middle East



Why FRC Global?

We show up for high-temp potential.

For over three decades, we have built strong partnerships by living up to our reputation of showing up for our customers. Our team is made up of hard-working people—many who have been in your shoes and understand the challenges you face. We are constantly thinking ahead, anticipating new barriers, and providing better solutions.

Our team knows that no two challenges are the same. When we show up to understand you and your operation, we study it to ensure we propose solutions, not just products.

As a company full of dedicated product managers and meticulous quality control teams, we travel around the

world to produce high-end products from only the best raw materials. With seasoned engineers on staff, we identify opportunities for performance and production improvements.

We are committed to excellence. Our strong relationships with global enterprises—primarily in strategic raw materials—ensure availability, performance, and consistent high quality. Our vast network serves as a cornerstone in our ability to deliver results on a global scale.

As proactive problem-solvers, we see your challenges as our own and look forward to achieving your project's greatest potential.



Flow Control

Product Description

Flow control products are absolutely critical to the safety, production and quality considerations of the end user. FRC Global has invested greatly in its ability to design, formulate, produce and deliver high-performance alumina-graphite and fused silica products.

Performance Highlights

- Safety is our mutual primary concern
- Custom-engineered products for your specific application
- CAD and modelling software available
- Formulations can be developed to achieve the right balance of cost and performance
- Zirconia (Zr) enhancements used in high impact areas such as the slag line.
- Every piece of alumina-graphite is inspected for flaws by X-ray
- Maximize productivity by recharging at the optimal time

Stopper Rods

Product Description

We offer ISO-statically pressed carbon bonded alumina-graphite stopper rods with enhanced composition wear bands. We also offer argon purging where necessary for the particular casting and cleanliness requirements of a shop. Various head compositions to ensure throttling control and a clean shut-off at the end of the casting sequence. A choice of designs with rigging supplied with the stopper as required.



Graphic Illustration

1. Multiple designs for attaching the rigging
2. Ceramic glaze coating to prevent external oxidation. High temperature glaze coatings are available for extreme preheat conditions.
3. Zr-based slag zone composition to ensure greater resistance to slag corrosion.
4. High quality AL-C materials having high corrosion and thermal shock resistance.
5. Porous plug to prevent steel from entering the stopper.
6. Spinel head materials having exceptional resistance to slag corrosion.
7. Mg-C head materials having good slag corrosion resistance when processing steel with Ca.
8. High quality Zr-based materials to ensure good corrosion resistance of the head.

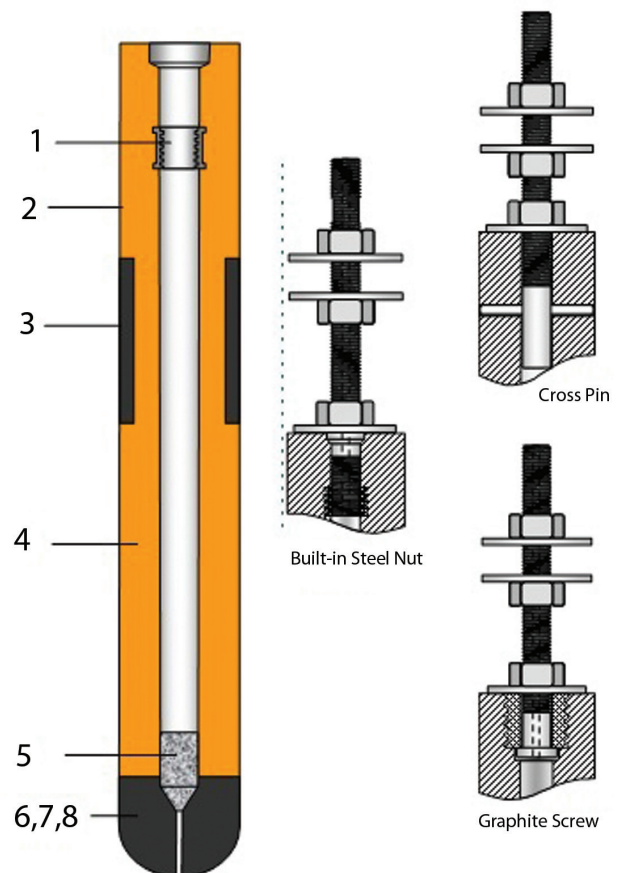

Ladle Shrouds

Product Description

ISO-statically pressed carbon bonded alumina-graphite ladle shrouds with enhanced composition wear bands and argon channels as necessary for the particular casting and cleanliness requirements of a shop. Preheat is not required as the shrouds are free of thermal shock characteristics. A variety of gasket designs and materials are also available for easy disconnect between heats.



Graphic Illustration

1. Multiple argon injection designs engineered for customer requirements.
2. Precision steel components for protection of the ceramic body.
3. Enhanced bowl composition for greater protection during lancing.
4. Ceramic glaze coating to prevent external oxidation.
5. Ceramic fiber to prevent heat loss during casting.
6. High quality Al-C materials having high corrosion and thermal shock resistance.
7. High quality composites to provide enhanced corrosion resistance at the slag line.
8. Non-graphite based materials to meet the requirements of producing low carbon steel, silicon steel and high purity steel.
9. Reverse taper and bell designs for the prevention of “blow-back” during submerged openings.

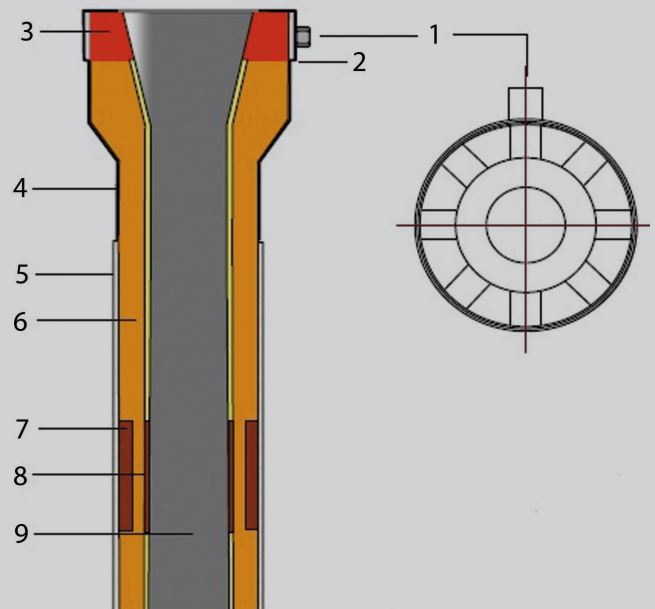

Alumina-Graphite SEN -SES

Product Description

ISO-statically pressed carbon bonded alumina-graphite SEN (sub-entry nozzles) and SES (sub-entry shrouds) with enhanced composition wear bands, argon channels and anti-clogging inner layers as necessary for the particular casting and cleanliness requirements of a shop.

Graphic Illustration

1. Multiple argon injection designs engineered for customer requirements.
2. Precision steel components for protection of the ceramic body.
3. Enhanced bowl and seat compositions for an improved seal.
4. Ceramic glaze coating to prevent oxidation during preheat. High temperature glaze coatings available for extreme preheat conditions.
5. Ceramic fiber to prevent heat loss during preheat and casting.
6. High quality Al-C materials having high corrosion and thermal shock resistance including compositions with special antioxidants for high O₂ steels.
7. High quality composites to provide enhanced corrosion resistance at the slag line.
8. Non-graphite based materials to meet the requirements of producing low carbon steel, silicon steel and high purity steel.
9. Anti-clogging inner layers and Slit SEN technology.

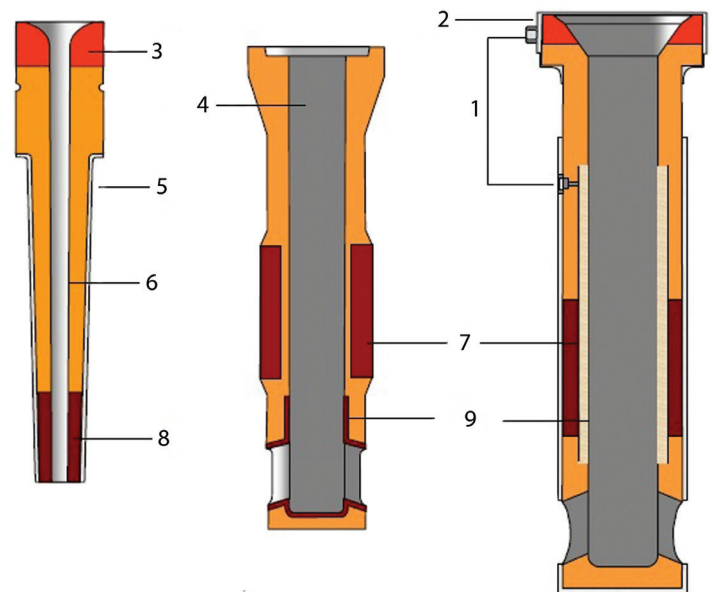
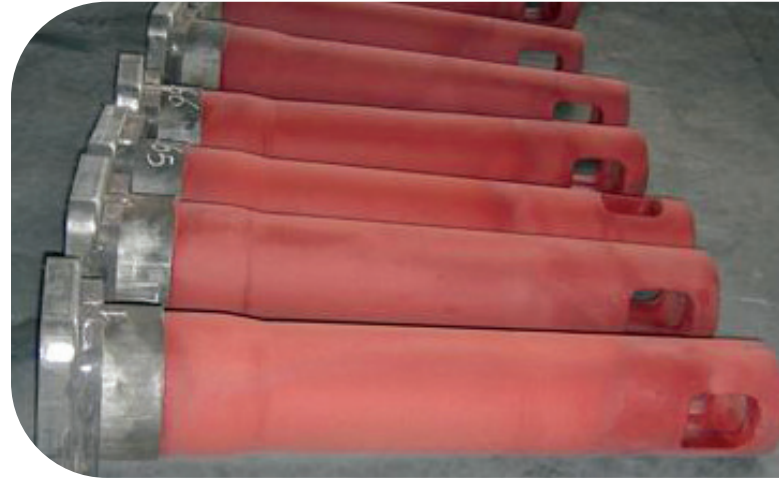

Tundish Upper Nozzles

Graphic Illustration

1. Al-C body materials having high corrosion and thermal shock resistance.
2. Enhanced Al-C materials for the bowl structure having high corrosion resistance.
3. Spinel compositions for the bowl structure to assure better adoption of the stopper including exceptional good resistance to slag corrosion.
4. Mg-based compositions for the bowl structure having good corrosion resistance to slag containing Ca.
5. Compositions to prevent Al_2O_3 adhesion inside the nozzle.
6. Argon injection designs to prevent air ingress.

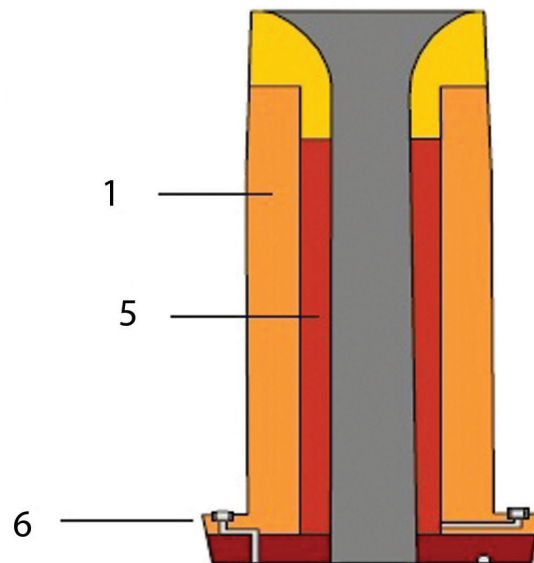
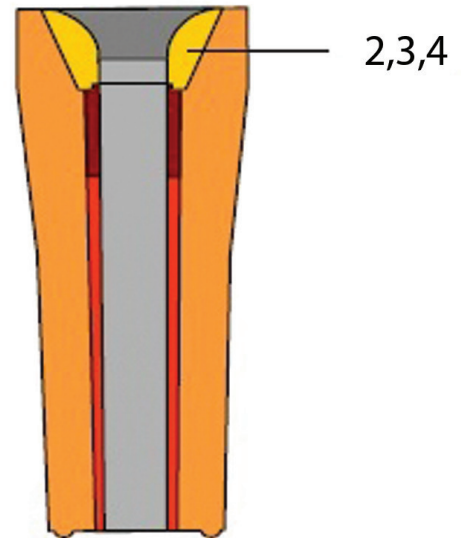

Quick Change & Thin Slab SEN

Product Description

ISO-statically pressed carbon bonded alumina-graphite SEN (sub-entry nozzles) and SES (sub-entry shrouds) with enhanced composition wear bands, argon channels and anti-clogging inner layers as necessary for the particular casting and cleanliness requirements of a shop.

Performance Highlights

1. Multiple argon injection designs engineered for customer requirements.
2. Precision steel components for protection of the ceramic body.
3. Enhanced bowl and seat compositions for an improved seal.
4. Ceramic glaze coating to prevent oxidation during preheat. High temperature glaze coatings available for extreme preheat conditions.
5. Ceramic fiber to prevent heat loss during preheat and casting.
6. High quality Al-C materials having high corrosion and thermal shock resistance including compositions with special anti-oxidants for high O₂ steels.
7. High quality composites to provide enhanced corrosion resistance at the slag line.
8. Non-graphite based materials to meet the requirements of producing low carbon steel, silicon steel and high purity steel.
9. Anti-clogging inner layers and Slit SEN technology.
10. Composite sliding surface materials to ensure sealing and fast change.

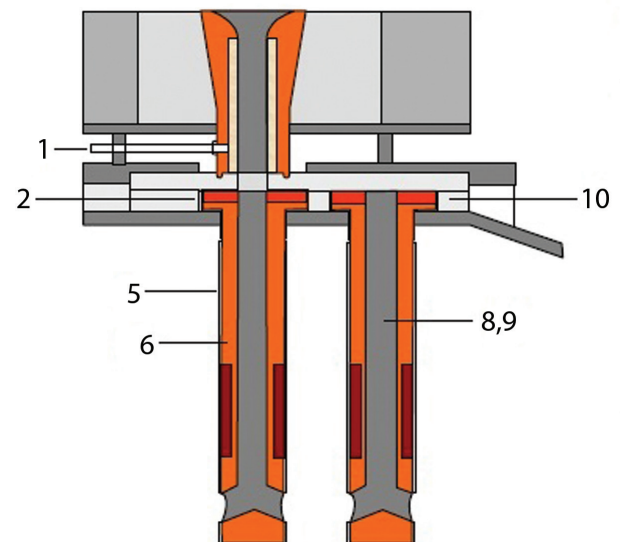
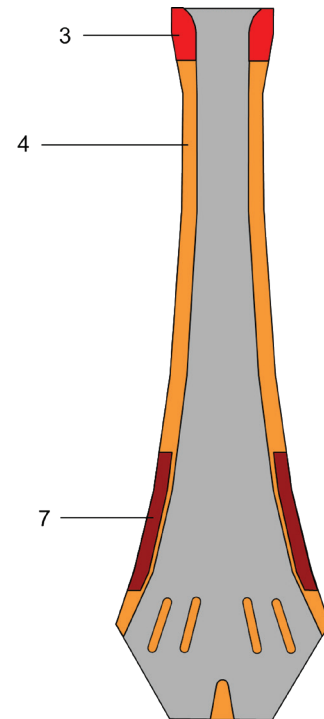



High Temp Innovation

United States

1000 N. West Street, Suite 1200 #3008
Wilmington, DE 19801

Canada

Montreal, Quebec

South America

Cali, Colombia
Phone: 011-57-310-826-2701

Asia

Dalian, China

1.800.609.5711

FRCglobal.com

